

# INTERNATIONAL<sup>®</sup> C-100 SERIES

MAXIMUM GVW, 5,000 LB.

MODEL	GVW RATING
C-100	4,200 lb.
C-102	5,000 lb.

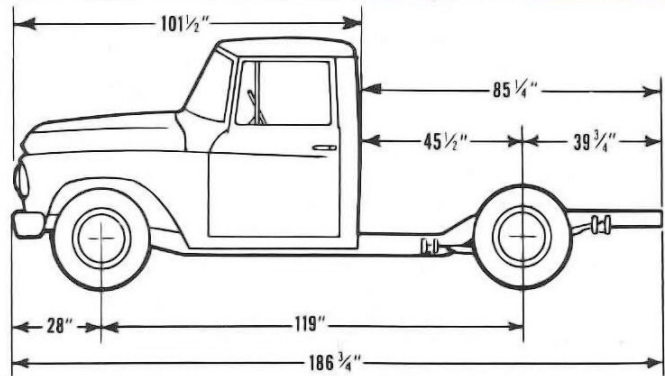

## CHASSIS DIMENSIONS

Dimensions are given in inches. Lengths are shown on diagram above. Other dimensions, based on use of 6.70 x 15 tires, include:

**Tread:** Front wheels, 62.2; rear, 62.5.

**Road Clearance:** Front, 8.6; rear, 7.8.

**Over-all Width:** Front, 78; rear, 69.4.

**Turning Radius** with bumper clearance: 21 3/4.

**Maximum Height** to top of frame from ground, at rear axle, loaded: 22.8.

**Weight** with cab, fuel, oil, water, standard Model C-100, approx.: 3265 lb.

## STANDARD SPECIFICATIONS

**Axle, Front:** FA-9. Rated capacity, 2,500 lb. Independent front wheel torque arm and torsion bar suspension.

**Axle, Rear:** RA-1. Rated capacity, 3,300 lb. Semi-floating, single reduction, hypoid type with 8 1/2-in. ring gear, overhung pinion, carbon steel axle shafts. Cast iron housing, bolted-on cover. Reduction, 3.54, 3.73 or 4.09 to 1.

**Brake, Parking:** Pedal applied, finger released, rear-wheel internal-expanding type. Effective lining area, 83 sq. in.

**Brakes, Service:** Hydraulic, one-way Servo front, duo Servo rear. Effective lining area, 187.4 sq. in.

**Cab:** All-steel with Sweep-Around windshield, side, rear and stainless steel-edged adjustable-tension Silent-Vent wing windows, all of safety glass. Adjustable full-width seat with nylon covered foam rubber seat cushion and cotton padded back cushion. Instrument panel with direct-reading gauges; chrome-plated control knobs. Safety type door latches; door locks both sides. Full-width floor with insulated mat. Vinyl-coated insulated headliner. Metal door trim panels. Dual two-speed electric windshield wipers. Inside overhead rear-view mirror. Left side sun visor. Ash tray. Map compartment.

**Clutch:** Hydraulic, 11-in. diameter, 9-spring, single plate, cushion dry disc, with coil spring vibration

damper. Facing area, 123.7 sq. in.

**Cooling System:** Centrifugal pump, balanced circulation with permanent by-pass for fast, even warm-up. V-belt drive. Fin-and-tube radiator. Large capsule type thermostat. Total capacity, 15 qt.

**Electrical System:** 12-volt. Pressure-centrifugal control type distributor. 50-amp-hr. capacity battery. Ignition key, solenoid-actuated, positive engagement drive starting motor. 30-amp. generator. Dual sealed-beam headlights. Nine-circuit fuse panel on firewall for wiring without circuit breakers.

**Engine:** INTERNATIONAL V-266, Y-block, short-stroke, low-friction, low-stress, eight-cylinder, gasoline, valve-in-head. Bore, 3 5/8 in.; stroke, 3 7/8 in.; displacement, 266 cu. in.; compression ratio, 8.4 to 1. Maximum brake horsepower, 154.8 at 4400 r.p.m.; maximum torque, 227.1 lb.-ft. at 2800 r.p.m. Five steel-backed, replaceable-shell, precision type main bearings. Five camshaft bearings. Nine rocker arm shaft supports. Slo-roto exhaust valves faced with heat-resistant alloy. Exhaust valve seat inserts. Hydraulic tappets. Water-jacketed intake manifold. Balanced assembly of crankshaft, flywheel and front pulley.

**Equipment, Standard:** Front bumper. Combination tail and stop light. Parking lights. Horn. Spare wheel.

**Finish:** Frame and wheels, black. Hood, cab and



**INTERNATIONAL TRUCKS — World's Most Complete Line!**

fenders painted in your choice of attractive solid standard colors. Anodized aluminum grille.

**Frame:** Welded steel box section, 5½ x 4¾ x ½ in., with ladder type crossmembers.

**Fuel System:** Horizontal diaphragm, mechanical fuel pump driven from camshaft. Fuel filter. Downdraft carburetor. Large capacity, high efficiency, oil bath air cleaner. Fuel tank, 17-gal., right side under cab.

**Lubrication System:** Full pressure feed to all main, connecting rod and camshaft bearings. Deep sump oil pan. External gear type oil pump; wire mesh floating oil strainer. Full-flow oil filter. Oil capacity (refill), 6 qt.

**Propeller Shaft:** Large-diameter, heavy-gauge steel tubing, dynamically balanced. Needle bearing, anti-friction universal joints.

**Springs:** Front—torsion bars, located for protection

from road spray and dirt. Rear—semi-elliptic steel leaves, 52 x 2½ in. Shock absorbers, direct acting, front and rear.

**Steering:** Semi-reversible, dual ratio, cam and roller-mounted twin lever gear. Four-spoke, 17-in., safety type steering wheel.

**Tires:** Front, single rear and spare, tubeless, 6.70 x 15PC, 4-ply. Tire carrier.

**Transmission:** T-1. Synchromesh type, with improved shift mechanism. Three speeds forward, one reverse. Remote control shift lever on steering column. Reductions—low, 3.039 to 1; second, 1.641 to 1; third, direct; reverse, 3.682 to 1.

**Wheels:** Disc type, 15-in. with 5.00 K rims. Chrome hub caps.

### OPTIONAL EQUIPMENT AT ADJUSTED COST

**Air Conditioner:** New, quiet, efficient unit with dual adjustable-position nozzles.

**Axle, Rear:** Rated capacity, 3,300 lb. Special with Powr-Lok differential, assures power to non-spinning wheel in sand, mud or on ice.

**Brakes:** Master-Vac power brake system.

**Bodies:** TRAVELALL® station wagon, 4 side doors, for 3 to 9 passengers. Standard body with single full-width seat, panel type rear doors. Custom body with second full-width intermediate fold-down seat, tail gate with electrically-controlled roll-down window, deluxe trim features. Third full-width rear seat available for both bodies. Intermediate seat and tail gate also optional for Standard body . . . Pickup body, 7-ft. inside length, Standard or flush-side Bonus-Load . . . Panel, 7-ft., with 4 side doors, bucket type driver's seat . . . Service-Utility, 79, 89 or 100-in., without or with fully-enclosed cargo area.

**Cab or Body Equipment:** Tinted glass. Special rear view mirrors. Arm rests. Right side sun visor. Glove compartment lock. Dome light. Cigar lighter . . . Auxiliary seat or full-width seat for panel body.

**Chassis Equipment:** Black rear bumper. Chrome front and rear bumpers. Special tire carrier. Spare tire lock.

**Clutch:** 10-in. diameter (for BD engine). 12-in. diameter, 12-spring (for V-8 engine).

**Electrical System:** 60 or 70-amp.-hr. battery. 50-amp. heavy-duty generator. 35 or 50-amp. charge-at-idle generator. 60-amp. AC-DC alternator. Dual stop and tail lights. Dual electric horns. Front corner and marker lights. Directional signals, Class A, front and rear.

**Engine:** INTERNATIONAL BD-220, I-block, high-torque,

six-cylinder, gasoline, valve-in-head. Bore, 3<sup>9</sup>/<sub>16</sub> in.; stroke, 3<sup>11</sup>/<sub>16</sub> in.; displacement, 220 cu. in. Maximum brake horsepower, 112.5 at 3800 r.p.m.; maximum torque, 194.4 lb.-ft. at 1600 r.p.m.

**Engine:** INTERNATIONAL BD-240, I-block, high-torque, six-cylinder, gasoline, valve-in-head. Bore, 3<sup>9</sup>/<sub>16</sub> in.; stroke, 4.018 in.; displacement, 240 cu. in. Maximum brake horsepower, 140.8 at 3800 r.p.m.; maximum torque, 223.5 lb.-ft. at 2000 r.p.m.

**Engine:** INTERNATIONAL V-304, Y-block, short-stroke, low-friction, low-stress, eight-cylinder, gasoline, valve-in-head. Bore, 3<sup>7</sup>/<sub>8</sub> in., stroke, 3<sup>7</sup>/<sub>16</sub> in.; displacement, 304 cu. in. Maximum brake horsepower, 193.1 at 4400 r.p.m.; maximum torque, 272.5 lb.-ft. at 2800 r.p.m. (for approved applications only).

**Engine Equipment:** High altitude equipment . . . Increased capacity cooling . . . Governor . . . Hand throttle control . . . Heavy-duty air cleaner.

**Heater and Defroster:** Recirculating and fresh air type.

**Power Steering:** Integral type. Cylinder, valve, reservoir and pump.

**Radio:** Push-button, semi-transistor, center-mounted on instrument panel.

**Springs:** Rear, progressive type or heavy-duty.

**Tires:** Tubeless or tubed, alternate sizes. Special treads. Underslung tubular tire carrier. Tire lock.

**Transmission:** Overdrive. Four-speed synchromesh.

**Transmission, Automatic:** Torque converter type. Three speeds forward, one reverse. Gear drive range selector mounted on steering column has Park, Reverse, Neutral, Drive<sup>2</sup>, Drive<sup>1</sup>, and Low positions. Eliminates need for clutch and pedal . . . Oil cooling unit.

*Specifications subject to change without notice.*

INTERNATIONAL HARVESTER COMPANY

180 NORTH MICHIGAN AVE. • CHICAGO 1, ILLINOIS

